

Safety Head Assemblies

Maximator safety head assemblies are used to provide over-pressure protection to high pressure systems. These safety head assemblies are to be used with the appropriate 1/4" angular rupture disc listed on the next page.

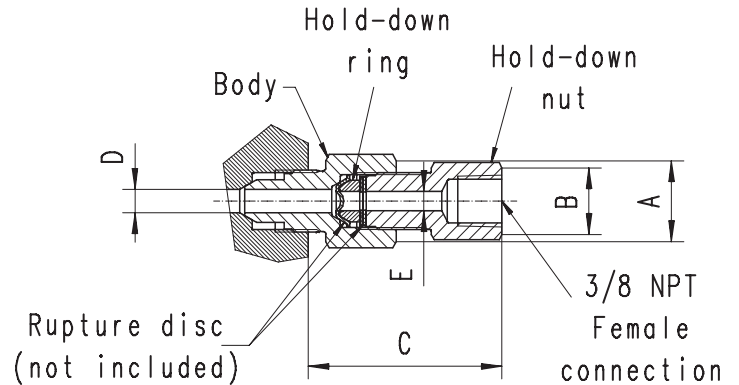
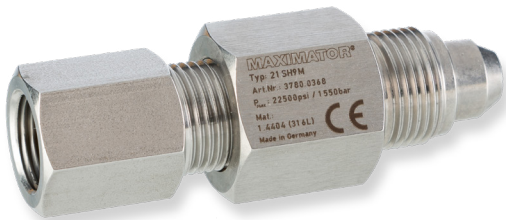

Safety Head Assembly Catalog Number without Disc	Fits Connection Type	Pressure Rating psi (bar)	Body Torque ft - lbs. (Nm)	Dimensions in. (mm)				
				A (Hex.)	B (Hex.)	C (LG.)	D (I.D.)	E (I.D.)
21SH4M	4MF	22,500 (1,550)	20 (30)	1,06 (27)	0,88 (22.3)	2,48 (63)	0,109 (2.8)	0,250 (6.3)
21SH6M	6MF	22,500 (1,550)	30 (40)	1,06 (27)	0,88 (22.3)	2,72 (69.1)	0,203 (5.1)	0,250 (6.3)
21SH9M	9MF	22,500 (1,550)	55 (75)	1,06 (27)	0,88 (22.3)	2,51 (63.7)	0,255 (6.5)	0,250 (6.3)
21SH12M	12MF	22,500 (1,550)	90 (120)	1,19 (30.2)	0,88 (22.3)	2,72 (69.1)	0,307 (7.8)	0,250 (6.3)
21SH16M	16MF	22,500 (1,550)	150 (200)	1,44 (36.6)	0,88 (22.3)	2,72 (69.1)	0,307 (7.8)	0,250 (6.3)

All dimensions for reference only and are subject of change

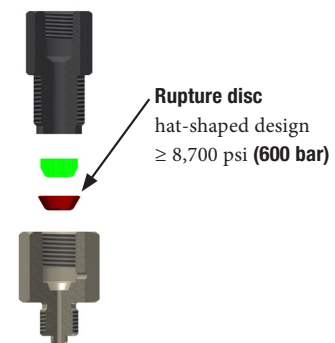

All technical and dimensional information subject to change. All general Terms and Conditions of sale, including limitations of our liability, apply to all products and services sold.