

Air Actuated H₂ Valves

Air Actuated High Flow Valves

- Standard type for hydrogen refilling stations for buses, trucks and trains
- Use for shut-off at compressor, distribution at gas storage banks
- Shut-off function for dispenser filling hose



Ordering Information
 Typical catalog number:
 15V9MO71-H2-8MNC

15 V Valve Series	9M O.D. Tube Size	07 Stem Type	1 Body Pattern	Configuration
15 V	9M – 9/16"	07 – VEE stem	1 – two-way straight	8MNC = Air-drive normally closed
			2 – two-way angle	

Technical Data and Dimensions

Technical Data

Operating temperature: -40° F / 185° F
 Drive pressure: 73 psi-145 psi (5-10 bar)
 Operating pressure: 15,200 psi (1,050 bar)

Materials

Valve body: 1.4404 (SST 316L)
 Valve stem: 1.4980 (A-286)
 Seal: UHMWPE

Dimensions

Height: 291 mm (11.45 in)
 Net weight: 16.8 kg (37 lbs)
 Width: 220 mm x 220 mm (8.66 in x 8.66 in)
 Orifice: 7.8 mm (0.307 in)
 Actuator: 8MNC



The valves are marked with an EX sign and are in conformity to Group II Category 2G Explosion group IIC constructive safety.

All technical and dimensional information subject to change. All general Terms and Conditions of sale, including limitations of our liability, apply to all products and services sold.

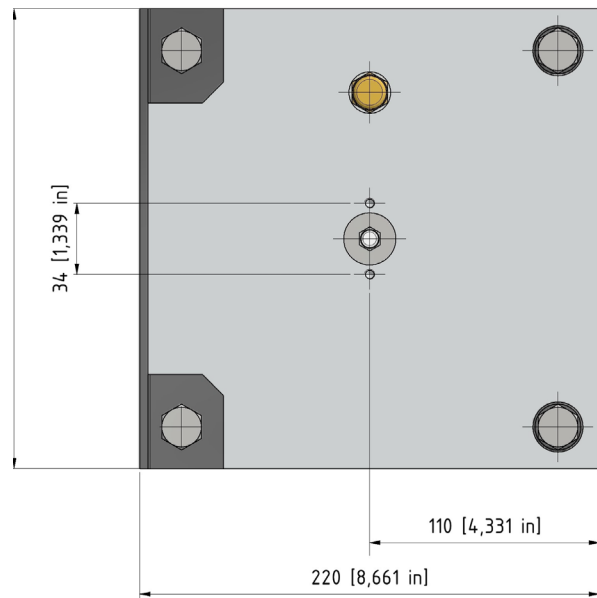
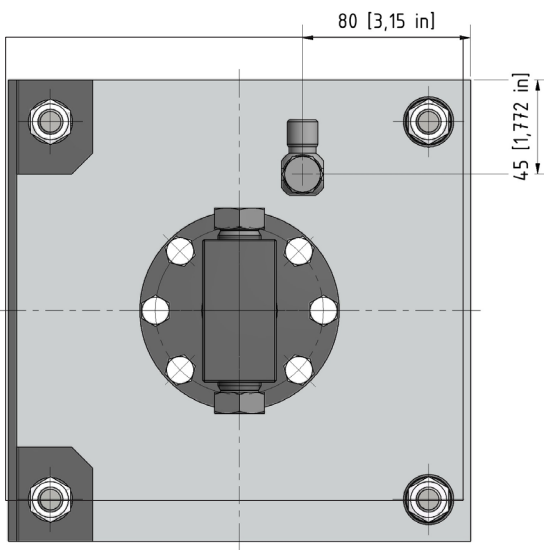
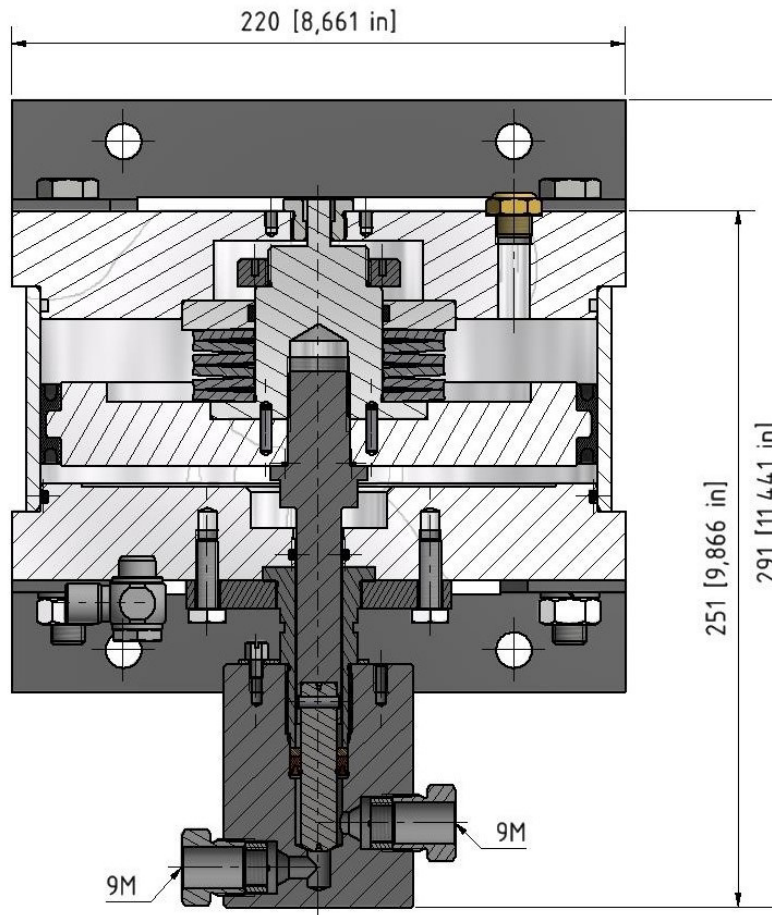

All technical and dimensional information subject to change. All general Terms and Conditions of sale, including limitations of our liability, apply to all products and services sold.