

Technical Data Sheet

Air Actuated H2-Valve 15V16M071-H2-10HNC

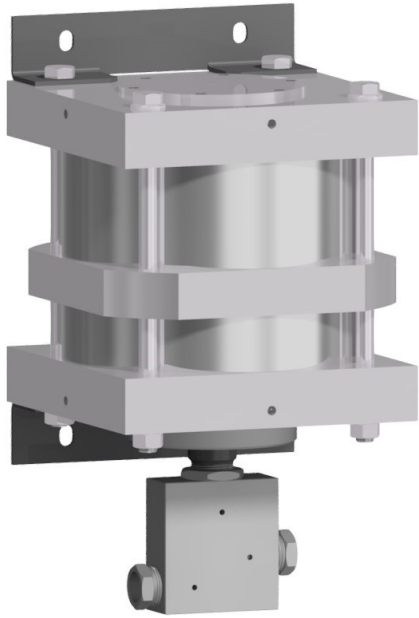

Technical Data

Operating temperature:	-40°C / +85°C
Drive pressure:	73 psi-116 psi (5 bar-8 bar)
Operating pressure:	15200 psi (1050 bar)
Net weight:	57,9 kg

Materials:

Valve body:	1.4404
Valve stem:	1.4980
Seal:	UHMWPE

Dimensions:

Height:	503 mm
Width:	270 mm x 270 mm
Orifice:	14,3 mm

Actuator: 10HNC

Catalog Part Number

Pressure	Component Type	Connection Size	Connection Type	Stem Type	Body pattern	Media	Configuration
15 = 15200 psi (1050 bar)	V = Valve	16 = 1"	M = Medium pressure	07 = Vee stem	1 = Two-way straight	H2	10HNC = Air drive normally closed
					2 = Two-way angle		



The valves are marked with an EX sign and are in conformity to Group II Category 2G/2D Explosion group IIC constructive safety.

Please consult factory for more information. All technical and dimensional information subject to change. All General Terms and Conditions of sale, including limitations of our liability, apply to all products and services sold.

15V16M071-H2-10HNC:

